

AFI-4M STAGE MONITOR

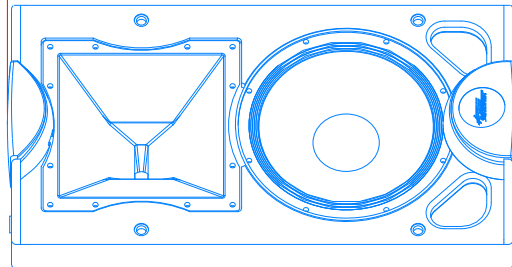

REVISIONS			
REV	DESCRIPTION	DATE	APPROVED
	REVISED	2-20-03	

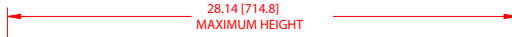
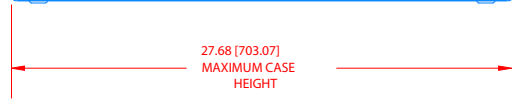
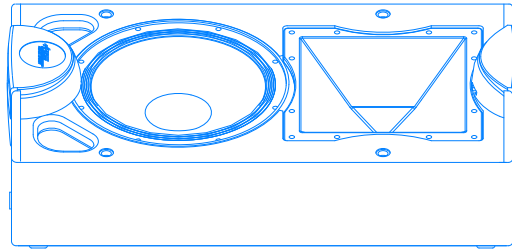
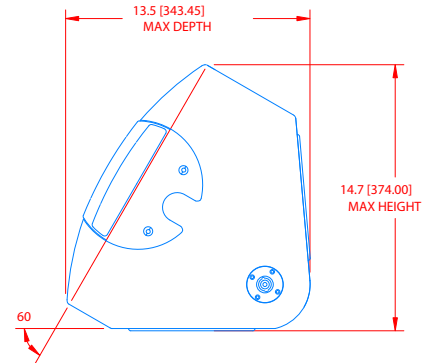
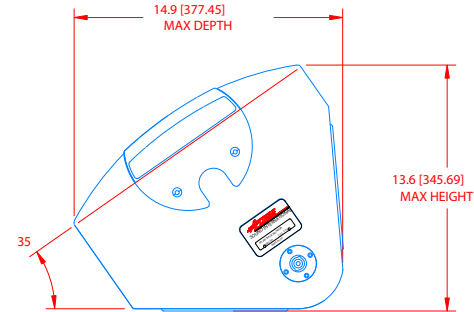

NOTE: DIMENSIONS ARE IN INCHES & [MILLIMETERS]

INFORMATION CONTAINED IN THIS DOCUMENT IS THE SOLE PROPERTY OF APOGEE SOUND INTERNATIONAL, LLC. REPRODUCTION OF ALL OR ANY PART OF THIS DOCUMENT WITHOUT WRITTEN PERMISSION FROM APOGEE SOUND INTERNATIONAL, LLC. IS PROHIBITED.

APPROVALS	DATE	APOGEE SOUND INTERNATIONAL, LLC <small>2180 SOUTH BALDWINVILLE BLVD. PISTONIA, CA 94954</small> <small>PHONE 707-578-8887 FAX 707-578-6922</small>	
DRAWN: AE	2-20-03		
CHECKED: MS	2-20-03	AFI-4M	
PART NUMBER		SIZE	FILE CODE
106-0450		SCALE: NT	DWG NO. ZF1004MA
		REV:	SHEET: 1 OF