

# APL-10 & APL-12

## SELF-POWERED CONCERT SUBWOOFER SYSTEM MANUAL



**APOGEE**  
**SOUND INTERNATIONAL**

© 2003 Bogen Communications  
Specifications subject to change without notice.  
55-0040-01D 0809

## Notice

Every effort was made to ensure that the information in this guide was complete and accurate at the time of printing. However, information is subject to change.

## IMPORTANT SAFETY INFORMATION

**WARNING:** To Reduce The Risk of Fire Or Electric Shock, Do Not Expose This Apparatus To Rain Or Moisture.

Always follow these basic safety precautions when installing and using the unit:

1. Read these instructions.
2. Keep these instructions.
3. Heed all warnings.
4. Follow all instructions.
5. Do not use this apparatus near water.
6. Clean only with dry cloth.
7. DO NOT block any ventilation openings. Install in accordance with the manufacturer's instructions.
8. Do not install near any heat sources such as radiators, heat registers, stoves, or other apparatus (including amplifiers) that produce heat.
9. Do not defeat the safety purpose of the polarized or grounding-type plug. A polarized plug has two blades with one wider than the other. A grounding-type plug has two blades and a third grounding prong. The wide blade, or the third prong, are provided for your safety. If the provided plug does not fit into your outlet, consult an electrician for replacement of the obsolete outlet.
10. Protect the power cord from being walked on or pinched, particularly at plugs, convenience receptacles, and the point where they exit from the apparatus.
11. Only use attachments/accessories specified by the manufacturer.
12. Unplug this apparatus during lightning storms or when unused for long periods of time.
13. Refer all servicing to qualified service personnel. Servicing is required when the apparatus has been damaged in any way, such as power-supply cord or plug is damaged, liquid has been spilled or objects have fallen into the apparatus, the apparatus has been exposed to rain or moisture, does not operate normally, or has been dropped.



**CAUTION: TO PREVENT THE RISK OF ELECTRIC SHOCK, DO NOT REMOVE COVER (OR BACK). NO USER-SERVICEABLE PARTS INSIDE. REFER SERVICING TO QUALIFIED PERSONNEL.**



The lightning flash with arrowhead symbol, within an equilateral triangle, is intended to alert the user to the presence of uninsulated "dangerous voltage" within the product's enclosure that may be of sufficient magnitude to constitute a risk of electric shock to persons.



The exclamation point within an equilateral triangle is intended to alert the user to the presence of important operating and maintenance (servicing) instructions in the literature accompanying the appliance.

# Table of Contents

Precautions & Safety Notes . . . . .	4
Introduction . . . . .	7
The Concept of Integration . . . . .	7
AC Power Requirements . . . . .	9
Audio Signals . . . . .	14
Controls . . . . .	15
Amplifiers . . . . .	16
Installation . . . . .	17
Signal Processing . . . . .	18
Using the APL-10/12 . . . . .	20
Troubleshooting & Field Repairs . . . . .	25
Troubleshooting . . . . .	28
Amplifier Back Panel . . . . .	29
Specifications . . . . .	31
Line Drawings . . . . .	32
Warranty Information . . . . .	IBC

# Precautions & Safety Notes

## English

- To reduce the risk of electric shock, disconnect the AC mains power cable before installing audio cable. Reconnect the power cord only after making all signal connections.
- Connect the loudspeaker only to a three-pole, three-wire grounding mains receptacle. The receptacle must be connected to a fuse or circuit breaker. Connection to any other type of receptacle poses a shock hazard and may violate local electrical codes.
- Do not install the speaker in wet or humid locations without using weather protection equipment from Apogee Sound.
- Do not allow water or any foreign object to get inside the loudspeaker. Do not put objects containing liquid on, or near, the unit.
- To reduce the risk of overheating the loudspeaker, avoid exposing it to direct sunlight. Do not install the unit near heat-emitting devices or appliances, such as a room heater or stove.
- The loudspeaker contains potentially hazardous voltages. Do not attempt to disassemble the unit. The unit contains no user-serviceable parts. Repairs should be performed only by factory trained service personnel.

## Français

- Pour réduire le risque d'électrocution, débrancher la prise principale de l'haut-parleur, avant d'installer le câble d'interface allant à l'audio. Ne rebrancher le bloc d'alimentation qu'après avoir effectué toutes les connexions.
- Branchez l'haut-parleur dans une prise de courant à 3 dérivations (deux pôles et la terre). Cette prise doit être munie d'une protection adéquate (fusible ou coupe-circuit). Le branchement dans tout autre genre de prise pourrait entraîner un risque d'électrocution et peut constituer une infraction à la réglementation locale concernant les installations électriques.
- Ne pas installer l'haut-parleur dans un endroit où il y a de l'eau humidité excessive.
- Ne pas laisser de l'eau ou tout objet pénétrer dans l'haut-parleur. Ne pas placer de récipients contenant un liquide sur cet appareil, ni à proximité de celui-ci.
- Pour éviter une surchauffe de l'haut-parleur, conserver-la à l'abri du soleil. Ne pas installer à proximité d'appareils dégageant de la chaleur tels que radiateurs ou appareils de chauffage.

- Ce haut-parleur contient des circuits haute tension présentant un danger. Ne jamais essayer de le démonter. Il n'y a aucun composant qui puisse être réparé par l'utilisateur. Toutes les réparations doivent être effectuées par du personnel qualifié et agréé par le constructeur.

## **Deutsch**

- Um die Gefahr eines elektrischen Schlags auf ein Minimum zu reduzieren, den Lautsprecher vom Stromnetz trennen, bevor ggf. ein Audio-Schnittstellensignalkabel angeschlossen wird. Das Netzkabel erst nach Herstellung aller Signalverbindungen wieder einstecken.
- Der Lautsprecher an eine geerdete zweipolige Dreiphasen-Netzsteckdose anschließen. Die Steckdose muß mit einem geeigneten Abzweigschutz (Sicherung oder Leistungsschalter) verbunden sein. Der Anschluß der unterbrechungsfreien Stromversorgung an einen anderen Steckdosentyp kann zu Stromschlägen führen und gegen die örtlichen Vorschriften verstoßen.
- Der Lautsprecher nicht an einem Ort aufstellen, an dem sie mit Wasser oder übermäßig hoher Luftfeuchtigkeit in Berührung kommen könnte.
- Darauf achten, daß weder Wasser noch Fremdkörper in das Innere den Lautsprecher eindringen. Keine Objekte, die Flüssigkeit enthalten, auf oder neben die unterbrechungsfreie Stromversorgung stellen.
- Um ein Überhitzen dem Lautsprecher zu verhindern, das Gerät vor direkter Sonneneinstrahlung fernhalten und nicht in der Nähe von wärmeabstrahlenden Haushaltsgeräten (z.B. Heizgerät oder Herd) aufstellen.
- Im Inneren diesem Lautsprecher herrschen potentiell gefährliche Spannungen. Nicht versuchen, das Gerät zu öffnen. Es enthält keine vom Benutzer reparierbaren Teile. Reparaturen dürfen nur von ausgebildetem Kundendienstpersonal durchgeführt werden.

## **Español**

- Para reducir el riesgo de descarga eléctrica, desconecte de la red el altoparlante antes de instalar el cable de señalización de interfaz de la señal. Vuelva a conectar el conductor flexible de alimentación solamente una vez efectuadas todas las interconexiones de señalización.
- Conecte el altoparlante a un tomacorriente bipolar y trifilar con neutro de puesta a tierra. El tomacorriente debe estar conectado a la protección de derivación apropiada (ya sea un fusible o un disyuntor). La conexión a cualquier otro tipo de tomacorriente puede constituir peligro de descarga eléctrica y violar los códigos eléctricos locales.

- No instale el altoparlante en lugares donde haya agua o humedad excesiva.
- No deje que en el altoparlante entre agua ni ningún objeto extraño. No ponga objetos con líquidos encima de la unidad ni cerca de ella.
- Para reducir el riesgo de sobrecalentamiento, no exponga la unidad a los rayos directos del sol ni la instale cerca de artefactos que emiten calor, como estufas o cocinas.
- Este altoparlante contiene niveles de voltaje peligrosos en potencia. No intente desarmar la unidad, pues no contiene piezas que puedan ser reparadas por el usuario. Las reparaciones deben efectuarse únicamente por parte del personal de mantenimiento capacitado en la fábrica.

# Introduction

Apogee Powered Loudspeaker Systems are highly-engineered products that combine advanced-technology amplifiers, sophisticated signal processing, and state-of-the-art drivers housed in rugged, roadworthy loudspeaker enclosures. They are suitable for a wide variety of applications, ranging from portable use for shows and events in all types of venues to permanent installations in auditoriums, churches, theaters, stadiums, meeting rooms, boardrooms, and similar locations.

The APL-10, and APL-12 are large format, high-powered subwoofers, capable of providing clean, undistorted low frequency sound at very high output levels. They form powerful arrays when used in multiples with like units. The enclosures are designed for easy truck-packing and handling, and can be safely flown from their built-in rigging points. They are designed to augment Apogee's full-range powered speaker family, but they are equally effective when used with conventional, non-powered loudspeakers. The APL-10 and APL-12 feature extended bass down to 34 Hz and 32 Hz, respectively, rapid transient response, and exceptionally low distortion, making them capable of fulfilling a wide range of professional sound reinforcement requirements.

Apogee powered products are exhaustively engineered and finely crafted. They will provide years of trouble-free service if care is taken in their use and maintenance. It is recommended that you read this manual and retain it in a convenient location for future reference.

# The Concept of Integration

## Why a Powered Loudspeaker?

Apogee's powered speaker systems further the concept of processor-based loudspeakers. By combining advanced electronic signal processing with precisely matched amplifiers and integrating this package into the speaker enclosure itself, a number of engineering improvements result. Some of these are:

- The internal signal processor corrects driver and enclosure anomalies, and provides required crossovers, time-domain alignment, and protection circuits.
- The amplifier's power output, headroom, frequency response, and dynamic range are optimized for each model of loudspeaker system.
- The gain structure of the signal processor and amplifiers are always perfectly matched.
- The amplifier output cables are kept to very short lengths, thereby reducing cable losses to nearly zero.

**These engineering advancements result in the following benefits:**

- All aspects of the loudspeaker system's performance are maximized. Sonic quality, power output capability, flatness of response, distortion, and behavior under abusive conditions meet remarkably high standards.
- Reliability is increased because the internal amplifiers deliver appropriate power levels to the drivers, without danger of over-powering or under-powering.
- Setup is quick and easy - all key circuitry is self-contained and factory-interconnected. There is no longer a need for the time-consuming mounting and wiring of processors and amplifiers in outboard rack enclosures.
- Powered speakers save valuable truck and stage space previously allocated for amplifier racks. Load-ins and load-outs are quicker and easier than with conventional systems.
- Powered speakers weigh less than equivalent non-powered speakers and amp racks, resulting in easier handling and reduced shipping costs.
- Powered speakers cost less and offer higher value than the equivalent non-powered speaker, processor, amplifier, and rack combination.



# AC Power Requirements

## (1) AC Power Connector and Cable

The APL-10/12 speakers use a PowerCon® 3-pole AC mains connector for their power inlet (see Figure #1). When joined to the mating PowerCon connector supplied with the AC line cord, the connector pair locks in place to prevent inadvertent disconnection. PowerCon connectors are durable, inexpensive, and readily obtainable.

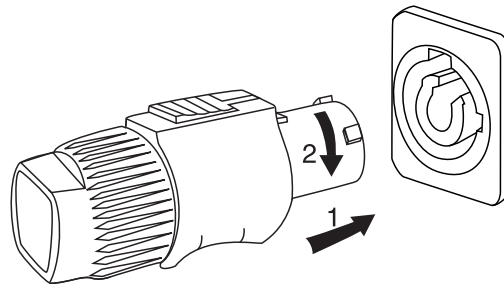
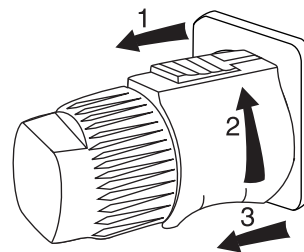

Figure 1



The AC PowerCon cable assembly provided with your APL-10/12 is equipped with an AC mains plug compatible with the power service in the country of sale. If you need to change this plug or to construct special purpose power cables, the wiring must follow the convention shown in Figure #2.

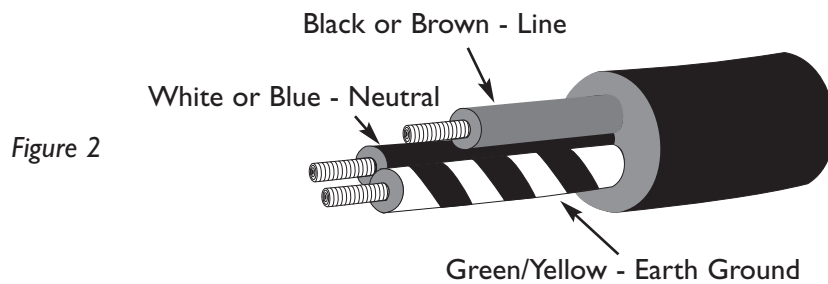
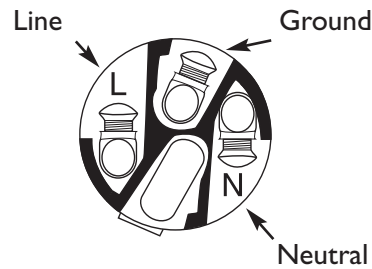

Figure 2

Figure 3



Interior of PowerCon connector showing the wiring terminal



All AC power plugs must always be of the 3-pole grounding type.



**DO NOT DEFEAT THE GROUND CONNECTION BY USING AN AC GROUND LIFT ADAPTER, OR BY CUTTING THE GROUND PIN OF THE AC POWER PLUG.**

## (2) Voltage Range

The APL-10/12 speakers use advanced, high efficiency, intelligent power supplies. A convenient external switch allows for easy conversion between 115V AC and 230V AC. In the 115V AC setting, the allowable line voltage range is 90V AC to 132V AC and in the 230V AC setting, the allowable range is 190V AC to 265V AC.



NOTE: The 115V AC model is suitable for use at 100V AC with only a small reduction in power capability.

Before applying power, carefully check the Line Voltage Switch Position on the rear panel located by the AC Mains Power Input connector to insure compatibility with the local AC mains supply.



Voltages above the rated maximum should be avoided at all times or damage may occur!

### (3) Current Requirements

All power amplifiers require sufficient current for proper operation and the amplifiers designed into Apogee powered loudspeakers are no exception. Chart #1 shows the required current for one APL-10 or APL-12 at three standard international working voltages (120, 240, & 100V AC). Because current drain is ultimately a function of the program source, Chart #1 shows both the theoretical maximum, and what can be expected under typical high-level program conditions:

Chart 1

<b>APL-10 / APL-12</b>	<b>100 / 120V AC</b>	<b>240V AC</b>
Max. Continuous Amperes	10.5A RMS	5.25A RMS
Typical Program Conditions	7A RMS (OR LESS)	3.5A RMS (OR LESS)

We recommend powering no more than one APL-10 or one APL-12 from a single 20A, 120V AC circuit, and no more than two APL-10 or APL-12 speakers from a single 20A, 240V AC circuit, thereby allowing a margin for line loss and/or lower than normal voltages.

To determine the total current requirement for a system of powered loudspeakers, simply add their Maximum Continuous RMS Currents together, then calculate a safety margin of 25% or greater.

If special length AC cables are required for your powered speakers, they should be constructed of durable, high-quality portable cordage such as S, SO, or SJO type.

Chart 2 provides the basic guidelines of The National Electric Code for four common gauges of copper wire related to permissible load in amperes.

Chart 2 applies to three-conductor portable cordage of the types S, SO, SP, SPT, SJ, and SJO, which are typically rated at a maximum operating temperature of 140°F (60° C). (NOTE: Operating temperature is the heat generated within the cable from the voltage drop added to the ambient temperature.) Chart 2 covers ambient temperatures of 86°F (30°C), 104°F (40°C), & 122°F (50°C).



For safety reasons, the maximum ratings in the table below should never be exceeded.

Chart 2

AWG#	Ambient Temperature		
	86°F (30°C)	104°F (40°C)	122°F (50°C)
14	15 A	12.3 A	6.9 A
12	20 A	16.4 A	8.7 A
10	25 A	20.5 A	14.5 A
8	35 A	28.7 A	20.3 A

(NOTE:AWG means American Wire Gauge.)



As you can readily see from Chart 2, the maximum permissible current ratings decrease rapidly as the ambient temperature rises. Carefully consider the ambient temperature in which the equipment will be used when determining appropriate wire gauge size.

#### (4) Voltage Drop

Another important consideration in determining appropriate wire gauge is the voltage drop that occurs across the cable's resistance. This is a function of the gauge and the length of the conductors, the current drawn by the load, and the AC mains voltage. Generally speaking, the permissible voltage drop should not exceed 2.5% of the working voltage for audio loads. Chart 3 shows voltage drop as a percentage of the nominal working voltage for typical lengths of cables in #14 AWG, #12 AWG, #10 AWG, and #8 AWG at 120V AC and 240V AC. The shaded areas show cable lengths and loads that result in 2.5% or less of voltage drop.

## POWER CABLE VOLTAGE DROP (IN PERCENTAGE OF NOMINAL VOLTAGE)

Chart 3

### #14 AWG, 120V AC

Length in Feet	5A	10A	15A	20A
25'	0.6%	1.2%	1.8%	2.4%
50'	1.2%	2.4%	3.6%	4.9%
75'	1.8%	3.6%	5.5%	7.3%
100'	2.4%	4.9%	7.3%	9.7%
125'	3.0%	6.1%	9.1%	12.2%
150'	3.6%	7.3%	10.9%	14.6%
175'	4.3%	8.5%	12.8%	17.0%
200'	4.9%	9.7%	14.6%	19.5%
225'	5.5%	10.9%	16.4%	21.9%
250'	6.1%	12.2%	18.2%	24.3%
275'	6.7%	13.4%	20.1%	26.8%
300'	7.3%	14.6%	21.9%	29.2%

### #14 AWG, 240V AC

Length in Feet	5A	10A	15A	20A
25'	0.3%	0.6%	0.9%	1.2%
50'	0.6%	1.2%	1.8%	2.4%
75'	0.9%	1.8%	2.7%	3.6%
100'	1.2%	2.4%	3.6%	4.9%
125'	1.5%	3.0%	4.6%	6.1%
150'	1.8%	3.6%	5.5%	7.3%
175'	2.1%	4.3%	6.4%	8.5%
200'	2.4%	4.9%	7.3%	9.7%
225'	2.7%	5.5%	8.2%	10.9%
250'	3.0%	6.1%	9.1%	12.2%
275'	3.3%	6.7%	10.0%	13.4%
300'	3.6%	7.3%	10.9%	14.6%

### #12 AWG, 120V AC

Length in Feet	5A	10A	15A	20A
25'	0.4%	0.8%	1.1%	1.5%
50'	0.8%	1.5%	2.3%	3.1%
75'	1.1%	2.3%	3.4%	4.6%
100'	1.5%	3.1%	4.6%	6.1%
125'	1.9%	3.8%	5.7%	7.7%
150'	2.3%	4.6%	6.9%	9.2%
175'	2.7%	5.4%	8.0%	10.7%
200'	3.1%	6.1%	9.2%	12.3%
225'	3.4%	6.9%	10.3%	13.8%
250'	3.8%	7.7%	11.5%	15.3%
275'	4.2%	8.4%	12.6%	16.8%
300'	4.6%	9.2%	13.8%	18.4%

### #12 AWG, 240V AC

Length in Feet	5A	10A	15A	20A
25'	0.2%	0.4%	0.6%	0.8%
50'	0.4%	0.8%	1.1%	1.5%
75'	0.6%	1.1%	1.7%	2.3%
100'	0.8%	1.5%	2.3%	3.1%
125'	1.0%	1.9%	2.9%	3.8%
150'	1.1%	2.3%	3.4%	4.6%
175'	1.3%	2.7%	4.0%	5.4%
200'	1.5%	3.1%	4.6%	6.1%
225'	1.7%	3.4%	5.2%	6.9%
250'	1.9%	3.8%	5.7%	7.7%
275'	2.1%	4.2%	6.3%	8.4%
300'	2.3%	4.6%	6.9%	9.2%

### #10 AWG, 120V AC

Length in Feet	5A	10A	15A	20A
25'	0.2%	0.5%	0.7%	1.0%
50'	0.5%	1.0%	1.4%	1.9%
75'	0.7%	1.4%	2.2%	2.9%
100'	1.0%	1.9%	2.9%	3.8%
125'	1.2%	2.4%	3.6%	4.8%
150'	1.4%	2.9%	4.3%	5.8%
175'	1.7%	3.4%	5.0%	6.7%
200'	1.9%	3.8%	5.8%	7.7%
225'	2.2%	4.3%	6.5%	8.7%
250'	2.4%	4.8%	7.2%	9.6%
275'	2.6%	5.3%	7.9%	10.6%
300'	2.9%	5.8%	8.7%	11.5%

### #10 AWG, 240V AC

Length in Feet	5A	10A	15A	20A
25'	0.1%	0.2%	0.4%	0.5%
50'	0.2%	0.5%	0.7%	1.0%
75'	0.4%	0.7%	1.1%	1.4%
100'	0.5%	1.0%	1.4%	1.9%
125'	0.6%	1.2%	1.8%	2.4%
150'	0.7%	1.4%	2.2%	2.9%
175'	0.8%	1.7%	2.5%	3.4%
200'	1.0%	1.9%	2.9%	3.8%
225'	1.1%	2.2%	3.2%	4.3%
250'	1.2%	2.4%	3.6%	4.8%
275'	1.3%	2.6%	4.0%	5.3%
300'	1.4%	2.9%	4.3%	5.8%

### #8 AWG, 120V AC

Length in Feet	5A	10A	15A	20A
25'	0.2%	0.3%	0.5%	0.6%
50'	0.3%	0.6%	0.9%	1.2%
75'	0.5%	0.9%	1.4%	1.8%
100'	0.6%	1.2%	1.8%	2.4%
125'	0.8%	1.5%	2.3%	3.0%
150'	0.9%	1.8%	2.7%	3.6%
175'	1.1%	2.1%	3.2%	4.2%
200'	1.2%	2.4%	3.6%	4.8%
225'	1.4%	2.7%	4.1%	5.5%
250'	1.5%	3.0%	4.5%	6.1%
275'	1.7%	3.3%	5.0%	6.7%
300'	1.8%	3.6%	5.5%	7.3%

### #8 AWG, 240V AC

Length in Feet	5A	10A	15A	20A
25'	0.1%	0.2%	0.2%	0.3%
50'	0.2%	0.3%	0.5%	0.6%
75'	0.2%	0.5%	0.7%	0.9%
100'	0.3%	0.6%	0.9%	1.2%
125'	0.4%	0.8%	1.1%	1.5%
150'	0.5%	0.9%	1.4%	1.8%
175'	0.5%	1.1%	1.6%	2.1%
200'	0.6%	1.2%	1.8%	2.4%
225'	0.7%	1.4%	2.0%	2.7%
250'	0.8%	1.5%	2.3%	3.0%
275'	0.8%	1.7%	2.5%	3.3%
300'	0.9%	1.8%	2.7%	3.6%



It's useful to note the benefit of operating a powered loudspeaker system at higher voltages (when possible). At 240V AC, current consumption is half that of 120V AC and the resultant voltage drop for a given cable size and length decreases by a factor of 4. This means that the cable can be four times longer when used at 240V AC than at 120V AC. **Higher voltages are more efficient!**

## Audio Signals

### (1) Input Impedance and Level

The APL-10/12 speakers were designed to receive a balanced-line signal on their 3-pin female XLR type connector. They are also equipped with a 3-pin Male XLR output connector, labeled "looping output," intended for the purpose of daisy-chaining multiple powered speakers together on a common signal feed. These input and output connectors are hard-wired in parallel; that is to say, no active or passive buffer exists between the two connectors, they are simply wired in parallel. This means that the loop-through connector will always remain functional, even if AC power is interrupted to a speaker "upstream" of other speaker(s) on the same feed circuit.

The input impedance is 35k-ohm, active balanced, and is intended to receive a nominal +4 dBv input level (+4 dBv = full power). Because it's common practice to loop quite a few powered speakers together on a shared feeder circuit, care must be taken to insure that the signal source is capable of driving the group of powered loudspeakers. For example, ten APL-12 speakers present a 3.5k-ohm load to the signal source. This is well within the capability of most line-level output drivers, but depending on the output impedance of the source, some loss in level may occur. The formula to calculate such loss is:

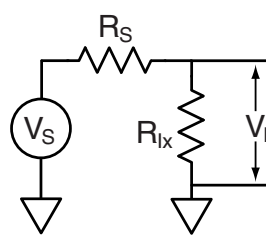

$$\text{Voltage Loss (dB)} = 20 * \text{Log} \left[ \frac{R_{ix}}{(R_{ix} + R_S)} \right]$$

Where:  $R_S$  = Source Equipment Output Impedance  
 $R_{ix}$  = Combined Input Impedance of all APL Speakers

Note:  $V_S$  = Unloaded Source Equipment Signal Voltage  
 $V_I$  = Loaded Signal Input Voltage to APL Speakers

For example, let's say you're driving ten APL-12 speakers with a 100-ohm source impedance. The formula to calculate loss would then be:

$$\text{Voltage Loss (dB)} = 20 * \text{Log} \left[ \frac{3500}{(3500 + 100)} \right] = -0.24 \text{ dB}$$



**NOTE:** It is important to be aware of the potential losses that may occur from combining multiple powered speakers on the same feed circuit. This is particularly important when attempting to adjust audio levels among a large system that employs multiple feed circuits with different numbers of powered speakers on each feed.

## (2) Input and Output Connectors

The input and output connectors are wired as follows:

<b>XLR Pin #</b>	<b>Function</b>
Pin 1	Earth & Chassis Ground
Pin 2   Signal +	DIFFERENTIAL INPUT
Pin 3   Signal -	DIFFERENTIAL INPUT
Connector Case	Earth & Chassis Ground

A positive signal applied to pin 2 of the XLR will result in a positive acoustic pressure wave (excursion) appearing at the front of the drivers in the speaker system. Conversely, a positive signal appearing at pin 3 of the XLR will result in a negative acoustic pressure wave (recursion) appearing at the front of the speaker system's drivers.

# Controls

## (1) Level Control

A single level control is located just above the XLR input. Under normal circumstances, the level control should be turned fully clockwise to the 0 position. This is full gain, or 0 dB of attenuation. In certain environments, for example, very quiet productions, it may be desirable to reduce the gain of the powered speaker to improve the overall gain structure of the entire audio system and possibly reduce system noise slightly. This is easily achieved by turning the level down to the desired amount of attenuation.

When multiple speakers will be attenuated, it is best to count the detent positions as the level control is adjusted. By doing this, you will be able to accurately set each speaker to exactly the same attenuation.

It is important to confirm that the level is set appropriately before deploying the speaker into a location where it will be difficult to reach.

## (2) Mute Control

Each channel of the internal amplifier has a user accessible mute button. Muting the LF1 or LF2 amplifier output can be useful in troubleshooting a system. The two buttons are labeled Ch1 and Ch2. Channel 1 is the LF1 amp and Channel 2 is the LF2 amp. Mute is enabled when the button is out. It is important to confirm that both buttons are depressed (un-muted) before deploying the speaker into a location where it will be difficult to reach in order to un-mute a channel.

### **(3) Indicators**

The APL-10/12 speakers have a green LED labeled PWR (Power) that indicates AC mains power is applied and the power supplies are functioning properly. A green Signal LED is above the level control. An amber LED just above the power LED indicates clipping. A red LED labeled PROT (Protect) is provided to indicate that the amplifier has gone into protect mode. Protect mode occurs under the following conditions:

- (a) The amplifier has exceeded its maximum safe operating temperature (the amplifier will automatically reset after cooling down).
- (b) The amplifier has failed and is outputting DC voltages that could damage the driver(s), or DC is present upstream of the amplifier due to component failure in the processor.
- (c) The driver(s) may have failed causing the amplifier to produce excessive output voltage.
- (d) The amplifier has failed to pass its automatic internal start-up test.

If conditions b, c, or d are encountered, the amplifier will latch in the Protect mode until the power is cycled to force a reset. However, if the fault condition has not been repaired upon power-up, the amplifier will again enter into the Protect mode.

## **Amplifiers**

### **(1) Overview**

The internal amplification package in both the APL-10 and -12 consists of dual, fully-independent amplifiers. Each amplifier is capable of delivering over 1200 watts of music power.

These amplifiers and power supplies use numerous, proprietary design features that result in extremely low distortion, high reliability, and a very low heat by-product. No fans are used or needed, eliminating the risk of a mechanical device becoming noisy during a quiet performance due to bearing wear or contamination. The absence of fans also greatly simplifies maintenance, by eliminating the need to regularly check and clean air intake filters.

The unique design of the amplifiers also results in the ability to provide exceptional transient response. This equates to a wider dynamic range and more low-frequency “punch” than that of conventional amplifiers of a similar power rating.



# Installation

When installing and using the APL-10/12, some simple precautions should be followed. These include:



## (1) Maintain Proper Air Flow

The APL-10/12 speakers are radiant- and convection-cooled devices. The aluminum heat-exchanger mounted on the rear surfaces provides primary cooling of the system. Care must be taken to locate the units away from heat registers, heat-generating appliances, lighting equipment, and any other apparatus that could raise the temperature of the nearby air.

The APL-10/12 speakers require unimpeded air circulation in order to function properly (this is especially important when multiple units are used in stacked and/or tight-pack configurations). The APL's rear surface should be located at least 18" away from walls and/or ceilings. Lamps, especially of the high intensity or theatrical type, should never be allowed to shine directly on the heat exchanger.

## (2) Ambient Temperature

The APL-10/12 speakers are designed to be used in ambient temperatures ranging from 32°F - 113°F (0°C - 45°C). Higher or lower temperatures could cause system shutdown or result in early component failure. When used outdoors on a hot day, take precautions to avoid direct sunlight on the rear heat exchanger. Direct, intense sunlight can raise the temperature of the heat exchanger to a point where the amplifiers may be required to shutdown to avoid permanent damage.

## (3) More About Heating and Cooling

The APL-10/12 speakers have a relatively complex thermal dynamic system. They contain several heat sources (amplifiers, power supplies, and drivers) that generate significant heat but only when program material is being reproduced. They are cooled primarily through heat radiation from the rear panel as well as by convection; and secondarily, by a small degree of air movement generated by the cone drivers.

Because the heat output of the system is directly proportional to the duration and nature of the program material, the system may not reach thermal stability for several hours after it is activated. For this reason, it is important to test the system under actual conditions of use if questionable conditions are present. Questionable conditions include:

- (a) ambient temperature at or above the maximum rating
- (b) intense sunlight or artificial light shining on the heat exchanger
- (c) program material that runs for many hours without pause
- (d) combinations of the above

**Here's a hypothetical example of what to look out for.** An APL-12 might be set up outdoors in 85°F (29°C) temperature with sunlight shining partially on the rear panel. Let's assume it is tested during a 30-minute sound check and all is well. Later that day, the ambient temperature rises to 99°F (37°C) and the sunlight is now shining directly on the rear of the loudspeaker. The show starts, featuring dance tracks with no pause between song titles. Under such extreme conditions, it is entirely possible that after a period of service, the loudspeaker will shut off to protect itself from excessive heat.

Problems, such as the one described above, can be avoided by shading the heat exchanger from direct sunlight.

## Signal Processing

### (1) Basic Concept

The APL-10/12 speakers use a highly-advanced signal processor contained entirely within the unit. The processor provides the functions of an asymmetrical electronic crossover (36 dB/octave low-pass and 24 dB/octave high-pass), fixed equalization to compensate for driver/enclosure anomalies, and advanced protective limiting circuits. It also provides a low-frequency alignment circuit that acts synergistically with the enclosure's ports. This serves to extend the bass response well below that of a conventional enclosure of a similar size. All circuits in the audio path utilize the highest quality, most up-to-date semi-conductor technologies available today.

The processor is the key to the extraordinary sound quality of the loudspeaker system. Unlike generic crossovers, either digital or analog, the APL processor was carefully designed in tandem with the drivers and the enclosure, to provide optimum performance.

### (2) Driver Protection

The APL-10/12 speakers utilize a special, highly-evolved set of limiter parameters and controls. Multiple limiters are used simultaneously with attack, release, integration time, and slopes that have been carefully matched to the individual speakers thermal and mechanical limits over time.

All of this occurs without compromising dynamic range or otherwise unnaturally compressing the program material. The protection circuits only act when the drivers would otherwise be damaged and, therefore, are exceptionally transparent. They are effectively "out of circuit" when below the threshold of engagement. The result is extremely clean sound quality, with effective protection of potential damage to the drivers under abusive conditions.

A clipping LED indicator is located on the rear panel. This LED will illuminate when the speaker is several dB into limiting and indicates maximum operating level has been reached. It is not uncommon to see the LED illuminate regularly, such as on downbeats and crescendos.

If the LED appears to be "ON" more than "OFF" (i.e., if they are continuously flashing or glowing at a steady state), the loudspeaker system is being pushed too hard for its size and power output capability. To correct this, reduce the drive level to the speaker system, or install additional speakers to achieve the SPL (Sound Pressure Level) required for the application.

### **(3) A Word About Limiters**

Properly designed protective limiters can do wonders to help prevent driver damage and extend normal driver life, but are by no means a panacea. Apogee limiters do not exhibit "brick-wall" characteristics, as these type of limiters seriously degrade sound quality. Apogee's intelligently engineered limiter circuits provide an excellent measure of protection, while maintaining sonic purity.



These limiter circuits are capable of effectively reducing program levels that would otherwise damage the system's drivers. This takes place with little or no loss of sonic quality or dynamic range, because the circuits are designed so that they only engage when driver non-linearity or driver damage would otherwise occur. However, when a limiter is pushed well past its threshold of engagement to the point where it is continually "in circuit", by nature, it increases the duty-cycle of the program material. This happens because, as the limiter decreases peak amplitudes, RMS values increase, causing the drivers to heat beyond normal. Additional circuits could be employed to reduce levels and "clamp" the output of the system, but such circuits would represent a high level of intervention and be very audible in their action. The proper solution is for the operator to recognize that the system is being pushed past its capabilities and either reduce operating levels or add additional speaker systems to provide the desired Sound Pressure Level (SPL).

# Using the APL-10/12

## (1) Overview

The APL-10/12 can be used in many ways and for many applications. In its simplest form, one APL-10/12 placed at each side of the stage will add dramatic low frequency impact to a typical full-range system in a club, church, or theatre.

A full-blown array of fifty or sixty APL-10/12 speakers, properly positioned, can provide intense low-frequency power for large-scale concerts, both indoors and out.

The nature of low-frequency sound waves and how they behave in space should be understood, at least in rudimentary form, to operate an APL-10/12 system to your best advantage. Low frequency waves are very long. A 30 Hz wavelength is approximately 35 feet in length and a 100 Hz wavelength is approximately 11.3 feet in length (varying a bit with temperature).

Because low-frequency waves are significantly greater in length than higher frequency waves, they behave quite differently than other wavelengths.

First, a long waveform does not 'see' a small or moderate-sized obstruction as an obstacle; it simply diffracts around the barrier as if it's not there. Second, the substantial length of low frequency waves makes it difficult to distinguish their source direction. (This is why a single subwoofer can often be used to augment a stereo pair of full-range speakers, without sacrificing stereo separation and image.)

Third, low frequency waves tend to join together very graciously (if they are in phase and in time with one another), even if their sources are separated by a considerable distance. Most professional sound engineers have experienced an intense bass elevation in the middle of certain rooms, generated by a stack of speakers placed at either side of the stage.

Understanding how low-frequency waves transmit can be very helpful in planning and designing optimum sound systems. There are many useful texts available on this subject. Recommended reading: "Fundamentals of Sound" and "Psychoacoustics" by F. Alton Everest in the "Handbook for Sound Engineers" published by Howard Sams & Co.

To help you get the most from your APL-10/12 powered loudspeakers, here are some basic guidelines.

## (2) Placement

The APL-10/12 will benefit greatly in terms of power output by being placed adjacent to a boundary surface (or surfaces). In practical terms, this means putting the APL-10/12 on the floor, on the ground, by a rear wall or ceiling (being careful not to restrict air flow to the heat exchanger), or in a corner.

When located by a wall (half space), power output will increase by 3 dB (see Figure 4) when compared to placement in a free-field environment (see Figure 5). When located at the junction of two walls (quarter space), power output will increase by 6 dB over that of a free-field environment (see Figure 6). Finally, when located at the junction of three walls (eighth space), power output increase a full 9 dB (see Figure 7).

It's not always possible to utilize walls and corners for extra power. The nearest wall or corner might result in the subwoofer being positioned behind the microphones, causing feedback, or, too far out of time sync with the full-range speakers. Sometimes the sound quality from a subwoofer located in a corner is not desirable due to other aspects of the room's acoustics. However, when wall and corner positions are appropriate to use, they offer a tremendous increase in power output.

Figure 4 - Half Space

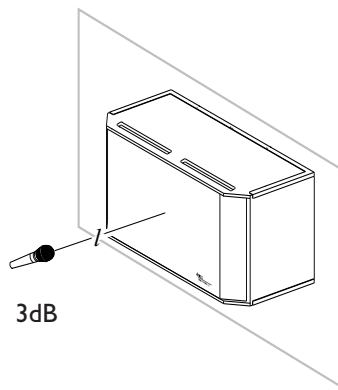

Figure 5 - Free Space

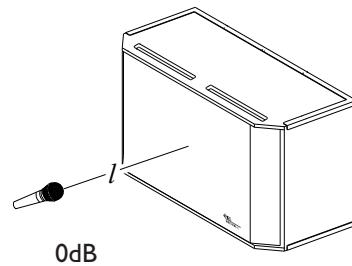

Figure 6 - Quarter Space

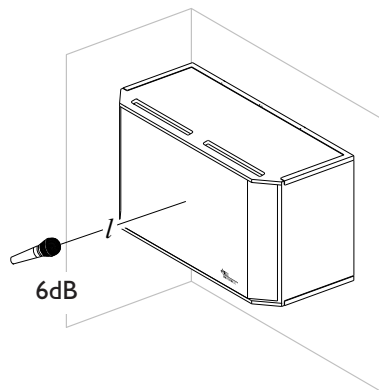
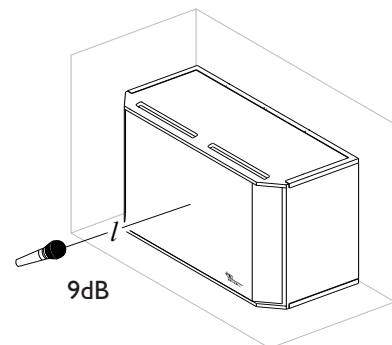

Figure 7 - Eighth Space



### (3) Configurations of Multiple Units

When the APL-10/12 is used in multiples, certain techniques can be applied to help achieve the desired results. To start with, the enclosures should be placed touching one another. Separating them, even a little, limits their power summation and can generate lobes and unwanted response anomalies.

Multiple units configured in a line will exhibit increased directionality in the axis of the line. For example, placing four or more APL-10/12 speakers horizontally end-to-end narrows their horizontal coverage pattern without changing the vertical pattern (NOTE: dispersion is essentially omni-directional for a single unit). Such a configuration can be used to increase the coverage distance in a large venue, such as a deep shed. Conversely, stacking four APL-10/12 speakers in a vertical line will narrow their vertical coverage angle without changing their horizontal dispersion. This configuration could be useful to penetrate long distances in a flat outdoor space, such as a soccer field.

**RULE OF THUMB:** Whenever the coverage angle is narrowed, on-axis power is also increased. The greater the number of enclosures placed in a line, the narrower the dispersion angle will be, with a corresponding increase in summation and forward-radiated power. The lowest frequency that will exhibit such behavior is directly a function of the array size.

The length of the array must be at least a 1/4 wavelength of the frequency of interest for any semblance of directional control to occur. At 1/2 wavelength, directional control starts to become effective. As the length of the line grows, directional control (i.e., narrowing of the dispersion pattern) increases continually, becoming more and more effective.

Chart 4 depicts wavelength vs. frequency (at ISO preferred frequencies) throughout the operating range of the APL-10/12, in relation to the number of APL-10/12 speakers that would approximate a 1/2 wavelength of the frequency of interest when arrayed end-to-end and top-to-bottom.

*Chart 4*

		<b>APL-10</b>	<b>APL-12</b>
Frequency in Hz	Wavelength feet / meters	No. end-to-end/ No. top to bottom	No. end-to-end/ No. top to bottom
25	44.8 / 13.7	9 / 12	6 / 9
31.6	35.6 / 10.9	7 / 9.5	5 / 7
40	28.3 / 8.6	5 / 7.5	4 / 6
50	22.5 / 6.9	4 / 6	3 / 4.5
63	17.9 / 5.4	3.5 / 5	2 / 3.5
80	14.2 / 4.3	3 / 4	2 / 3
100	11.3 / 3.4	2 / 3	2 / 2

APL-10/12 speakers can also be combined in an L-format (See Figure 8). The L-format exhibits directional control in both axes, and is often the best choice for deploying a large number of speakers in sizeable venues.

Figure 8

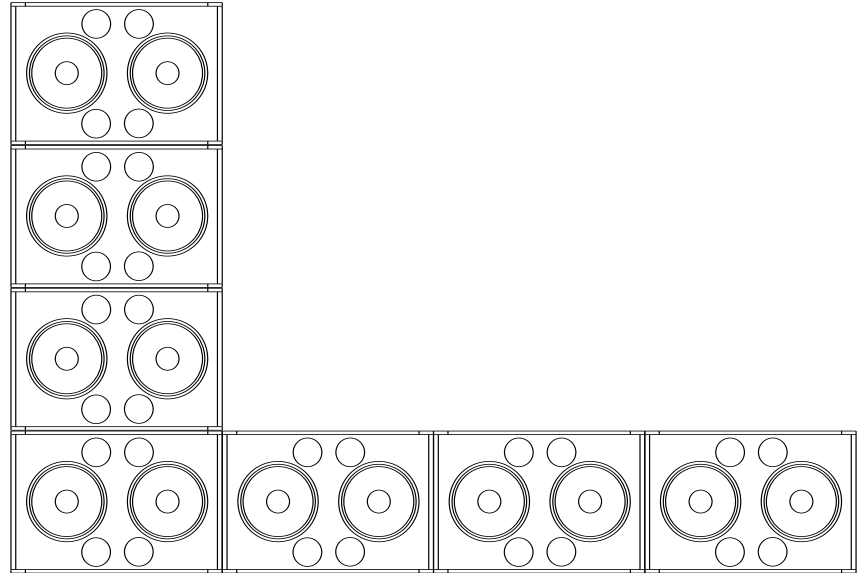

Finally, APL-10/12 speakers can be configured into a block arrangement (See Figure 9). This arrangement also exhibits directional control in both axes, but it does not take full advantage of the boundary surface effect (see "Using the APL-10/12 – (2) Placement" (pg. 20). Although this configuration is certainly more effective than scattering the units about at random, it has a tendency to produce unwanted lobing, sometimes leading to a muddy bass response.

Figure 9

#### (4) Flying the APL-10/12

For many applications, the APL-10/12 subwoofer may need to be flown. This commonly occurs with television award shows, political conventions, and other events where the audience is located too close to the stage to allow the subwoofers to be placed in the typical side or front-of-stage position. APL-10/12 speakers perform perfectly well when flown; in fact, the sound quality is often perceived as being superior when the speakers are in the air as opposed to on the ground. This is usually because they integrate better with the flown full-range speakers when they are in close proximity to them, although it can also be because of the acoustical characteristics of a given room, or a combination of both. However, be aware that the same number of units that performed satisfactorily on the ground or in a corner will have to be doubled or tripled to achieve the same power output level when they are flown.



The APL-10 and -12 are equipped with four rigging points – two on the top and bottom of the APL-10 – and two on either side for the APL-12. These points are supplied with either Apogee nutplates or Aeroquip pan-fittings, as specified at purchase (fitting types can be changed easily in the field to accommodate changing requirements). If the rigging fittings are to be changed, *always use the screws that are supplied from the factory* – never use generic screws purchased at a hardware store because they are unsafe for this application!

Nutplates are circular steel plates with a welded 3/8-16 threaded fastener in the center, designed to accept 3/8-16 threaded bolts (also available in Metric M-10 version). Each nutplate can sustain a straight-line-of-force load of 2500 lb. (1136 kg) before failure. An APL-12 weighs 214 lb. (97 kg), so if only two nutplates are used to suspend the speaker, the safety factor is 23:1 (NOTE: OSHA requires a 5:1 safety factor, whereas most theatrical rigging shops have voluntarily adopted a 7:1 safety factor.).



It is vitally important that all hardware used to suspend the APL-10/12 be of the highest grade materials and construction. All bolts must be SAE Grade 7 or better. The American bolt-grade rating system is often depicted by a number of linear hash marks on the head of the bolt – five marks mean Grade 7, six marks mean Grade 8.

If eyebolts are used, they must be forged and of the shoulder-type. Eyebolts are designed for a straight-line-of-force. They de-rate rapidly and become unsafe as the load angle deviates from the 0 degree axis (in line with the length of the threaded bolt).

All bolts must be tightened securely, but not over-tightened (5-7 ft. lb. of torque is generally sufficient for 3/8" bolts). Over-tightening can cause much of the tensile strength of the bolt to be used up, before any external load is placed on it. An exception to this rule is when the bolt is used in sheer, such as when rigging plates are attached to the side of a speaker. In sheer, the friction provided by tightening and *preloading* the bolt actually increases the strength of the joint and decreases cyclic failure of the fastener.





**Consult an experienced rigger or engineer when it comes to rigging practices, methods, required materials, or other details.** The kinetic energy from a 214 lb. object falling 40 feet onto a solid surface is truly astounding. Injury or loss of life could occur, even to those who are not in close proximity, let alone the injuries or deaths that may result from a panicked crowd. Safety is the most important part of the job! Take the extra time to obtain the proper rigging materials and components, or *keep the system on the ground!* All rigging fittings, slings, Spansets™, shackles, bolts, and other equipment should be inspected carefully before each use. Questionable components or materials should immediately be discarded where they won't be found and re-used by someone else. In particular, forged eyebolts, shackles, pins, and other high-carbon steel components are susceptible to fracture, if they fall even a few feet onto a hard surface like a concrete floor. *Play it safe and do not use any questionable components or materials!*

## Troubleshooting & Field Repairs

### (1) General

Troubleshooting the APL-10/12 is a simple process. With an integrated system, there's really not much that can go wrong. If a problem does arise, it usually can be solved quickly by performing the processes described below.



All repair work that involves dismantling the APL-10/12 must be performed by a qualified, trained service technician. The power cable must be disconnected before attempting any repair work. Lethal voltages are present inside the APL-10/12 when the power cable is connected!

### (2) Drivers

The APL-10 employs dual 15" high power cone drivers and the APL-12, dual 18" high power cone drivers. All are treated with Ferrofluid™ as a dampening and heat conduction agent. Additionally, the cone surfaces are treated with a proprietary compound that makes them highly resistant to water damage. This compound has an important secondary purpose: the cones will not change mass due to moisture absorption in humid weather, making the system's sonic qualities exceptionally stable when used in varying climactic conditions.

Occasionally, due to mechanical shock or abusive operation, a driver may become dysfunctional. Drivers can fail completely, or they can fail in such a way that they continue to reproduce sound but their output becomes noticeably distorted. The latter is usually due to deformation of the voice coil, resulting in the coil rubbing against the gap. In either case, driver replacement is warranted.

To verify if a driver has failed, remove the front grille and listen to the system at a moderate level. By lightly touching each driver while playing program material, you can readily tell if it is actively radiating or passively responding to the other driver's pressure.



Before attempting to replace any parts in the APL-10/12, be certain to disconnect the power cable from the unit. Lethal voltages are present inside the enclosure when the unit is connected to an AC mains supply!

The drivers in the APL-10/12 can be changed in just a few minutes. To gain access, first remove the front protective grille with a Phillips screwdriver. After the grille is removed, the driver itself can be removed by simply loosening the eight (8) Allen-drive fasteners that retain it, and lifting it out of the enclosure. If possible, perform this task with the enclosure resting on its rear surface. This will ease the process and minimize the force that would otherwise be placed on the driver as the fasteners are loosed, if the enclosure were upright. To remove the driver after the eight Allen-drive fasteners have been taken out, reach through the nearest bass port with your hand and push the driver upwards. The gasket sometimes sticks a bit, so do not hesitate to use a little force to unseat the driver from the gasket.

Once the driver has been removed from the enclosure, disconnect the speaker wires from the terminals. To replace the driver, simply reverse the disassembly process, making sure to connect the speaker wires properly. The black wire goes to the black terminal on the driver, and the red or white wire goes to the red terminal on the driver.



**NOTE:** If the driver is connected backwards (out of phase), it will not function properly and could be damaged rapidly. It could also damage the other driver in the enclosure.

After the driver is connected, place it carefully over the opening and rotate it to align its holes with the eight threaded inserts in the enclosure. Then, install the fasteners, being careful to tighten them gradually in a cross-pattern so as to equalize the force placed on the driver's rim. Do not over-tighten the fasteners or the driver's rim may become warped! Two to three foot-pounds of torque is sufficient.

After replacing the driver, power up the speaker system and play some program material through it before replacing the grille. Verify that the new driver is operating properly. If the system still exhibits problems, it may need additional service work.

### **(3) Amplifier Removal & Replacement**



Before attempting service work, be certain to disconnect the power cable from the unit. Lethal voltages are present inside the enclosure when the unit is connected to an AC mains supply!

The amplifier package consists of the power supply, amplifiers, and processing electronics. It is held in place by twelve (12) 8/32 Phillips drive fasteners.

Once the fasteners are free, the amplifier assembly can be easily disconnected from the drivers. All other cables and connections are contained within the assembly. The entire assembly can be replaced in a matter of minutes by reversing the removal process. Make sure to tighten the fasteners gradually in a cross-pattern, to avoid warping the enclosure material.

# Troubleshooting

PROBLEM	SUGGESTIONS
<p><b>POWER LED illuminates but audio is not present</b></p>	<ul style="list-style-type: none"> <li>• Check to be sure that the signal feed cable has audio present. This can be done by plugging it into a speaker/amplifier that is known to work, or, by using a portable powered headphone/amplifier test set such as the Shure™ FP22.</li> <li>• Make sure the signal feed cable is securely mated with the XLR input connector.</li> <li>• Substitute an alternate cable to determine if the cable is at fault.</li> </ul>
<p><b>The system exhibits hum or noise</b></p>	<ul style="list-style-type: none"> <li>• Disconnect the input cable. If the hum or noise ceases, the problem is either in the source, or it may be caused by a ground loop created when the source is connected to the APL-10/12. Listen to the source with an alternate speaker/amplifier or a headphone test set, to determine if the source is clean.</li> <li>• If the source is clean, try installing an XLR ground lift adapter to the input cable.</li> </ul> <p style="text-align: center;">  <b>DO NOT, UNDER ANY CIRCUMSTANCES, ATTEMPT TO LIFT THE AC GROUND CONNECTION! LIFTING THE AC GROUND COULD RESULT IN INJURY OR DEATH!</b> </p>
<p><b>The audio sounds compressed or distorted and the limit light is NOT registering.</b></p>	<ul style="list-style-type: none"> <li>• Check the input source with an alternate speaker/amplifier or a headphone test set, to determine if the source is clean.</li> <li>• Check to be sure the input cable is properly mated.</li> <li>• Listen to an alternate source with the same APL-10/12 to determine if the source or the loudspeaker is malfunctioning.</li> </ul>
<p><b>The audio sounds compressed or distorted and the limit light is registering.</b></p>	<ul style="list-style-type: none"> <li>• Reduce the drive level to the speaker system.</li> <li>• Increase the number of loudspeakers used in the system if the desired level cannot be obtained with the present number of loudspeakers.</li> </ul>

# Amplifier Back Panel

## Line AC Panel of an Apogee APL Subwoofer

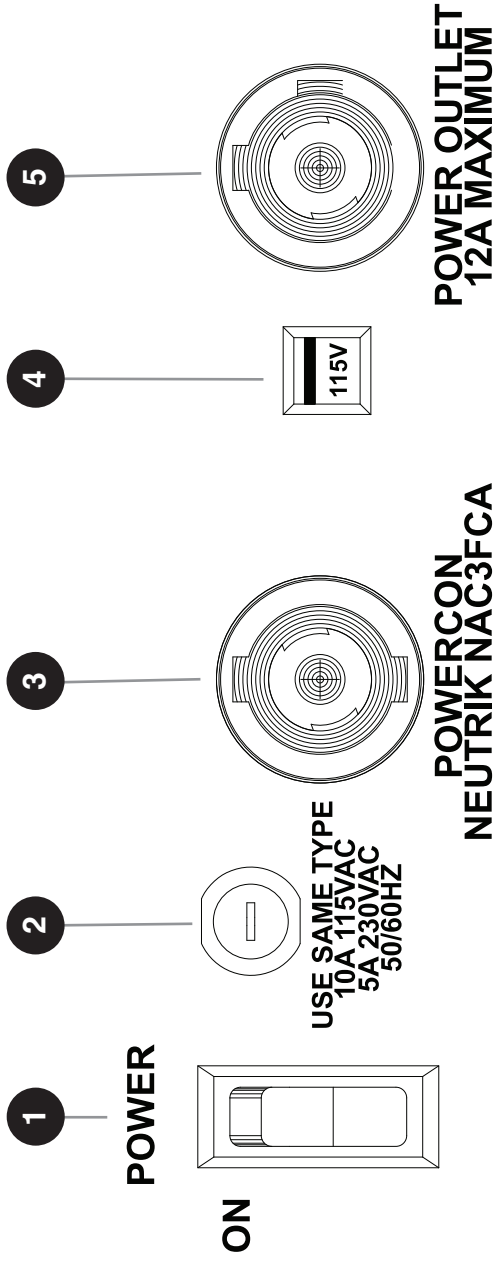

- 
- 1 Power Switch
  - 2 Main AC Protection Fuse
  - 3 AC Input Connector, Neutrik Powercon NAC3FCA
  - 4 AC Line Voltage Selection Switch
  - 5 AC Output Connection, Neutrik Powercon NAC3FCB

# Audio Input Panel of an Apogee APL Subwoofer

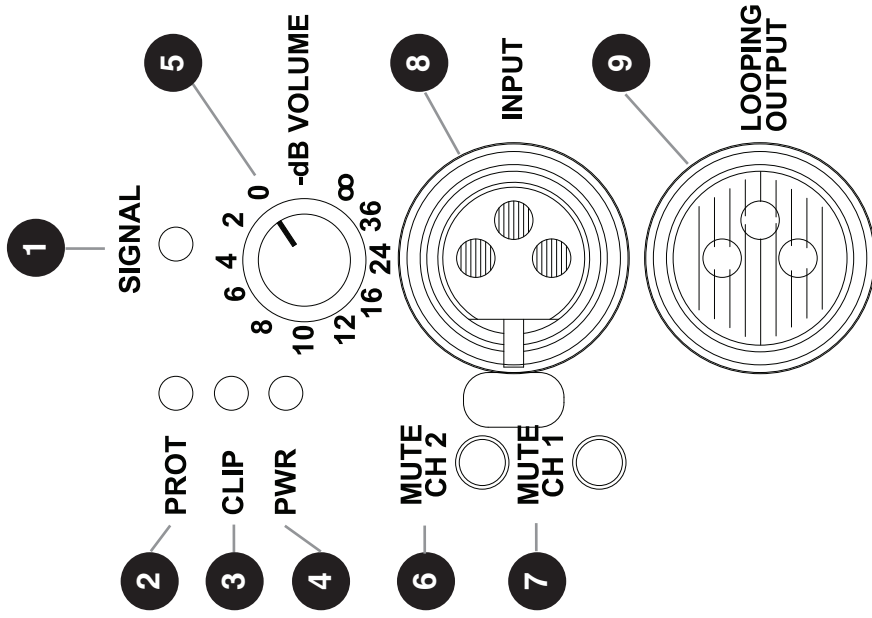

- 1 Signal Presence Indicator
- 2 System Protection Indicator
- 3 Amplifier Clip Indicator
- 4 System Power Indicator
- 5 Volume Control
- 6 Ch 2 Mute Switch
- 7 Ch 1 Mute Switch
- 8 Balanced Line Audio Input, XLR
- 9 Balanced Line Audio Loop-through, XLR

# Specifications

	<b>APL-10</b>	<b>APL-12</b>
<b>Enclosure Type</b>	20° Trapezoidal, optimally-vented bass	Rectangular, optimally-vented bass
<b>Format</b>	Self-contained dual power amplifiers with integrated processing electronics	
<b>Frequency Response</b>	34 Hz to 100 Hz ± 3 dB (on axis)	32 Hz to 100 Hz ± 3 dB (on axis)
<b>Dispersion</b>	Omni-directional	
<b>Max. SPL</b>	131 dB cont./ 137 dB peak (@1m)	134 dB cont./ 140 dB peak (@1m)
<b>Dimensions</b>	32" W X 22.5" H X 24" D (813 X 572 X 610mm)	44.75" W X 30" H X 22.5" D (1137 X 762 X 572mm)
<b>Drivers</b>	Dual Apogee 15" with Ferrofluid®	Dual Apogee 18" with Ferrofluid®
<b>Input</b>	XLR, active balanced 35k ohms, with loop-through output connector	
<b>Amplifier Output Power</b>	2400W total music power, dual amplifiers	
<b>RMS Limiter</b>	100ms integration time, long duration protection, VIPROTECT™	
<b>Peak Limiter</b>	3 to 5ms fast-acting transient protection, VIPROTECT™	
<b>Product Weight</b>	145 lb. (65.8 kg)	214 lb. (97 kg)
<b>AC Voltage</b>	115V AC or 230V AC selection switch on back panel; Neutrik Powercon™ connector with loop-through	

# Line Drawings

## APL-10 SELF-POWERED SUBWOOFER

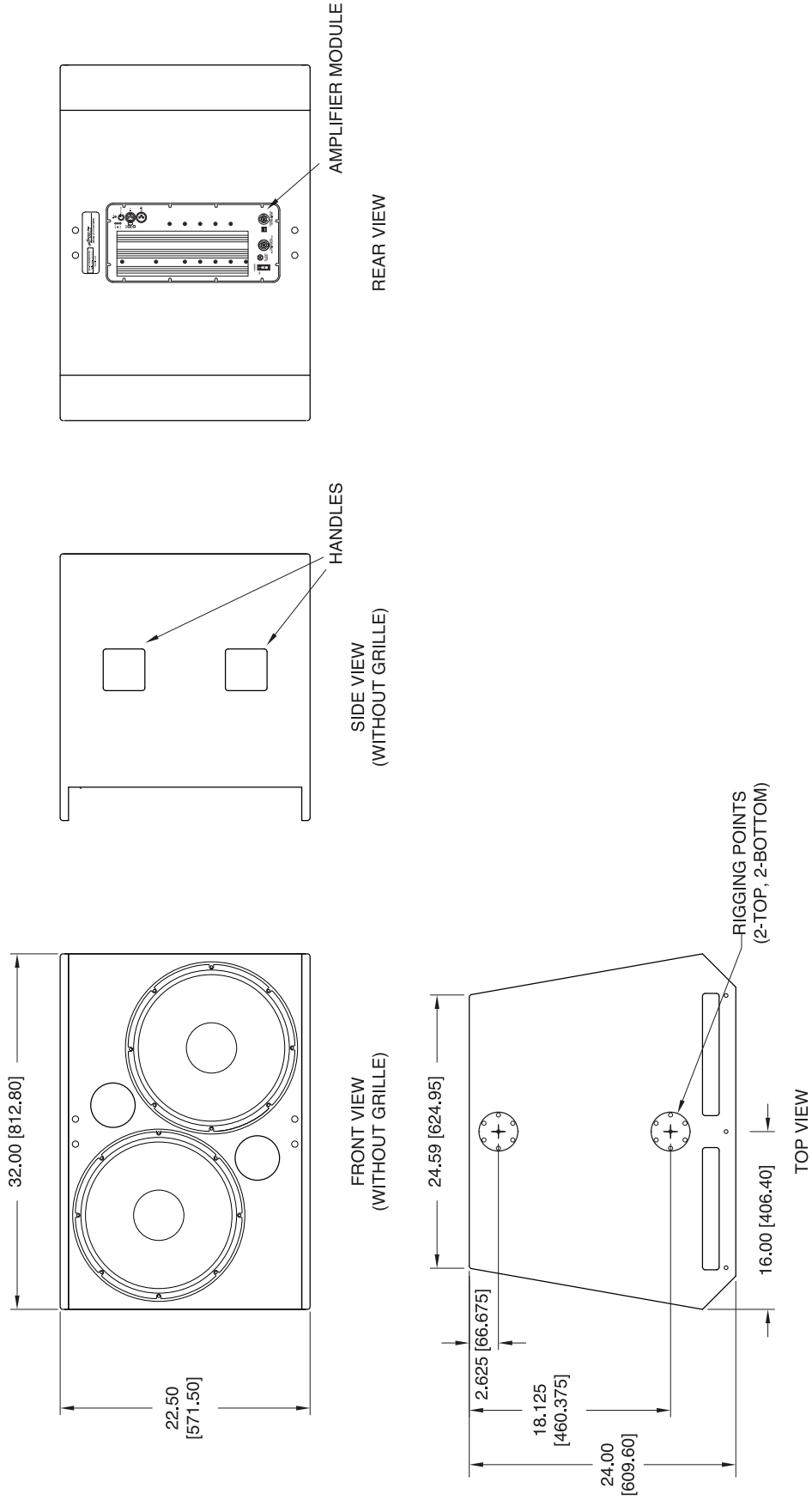



# APL-12 SELF-POWERED SUBWOOFER

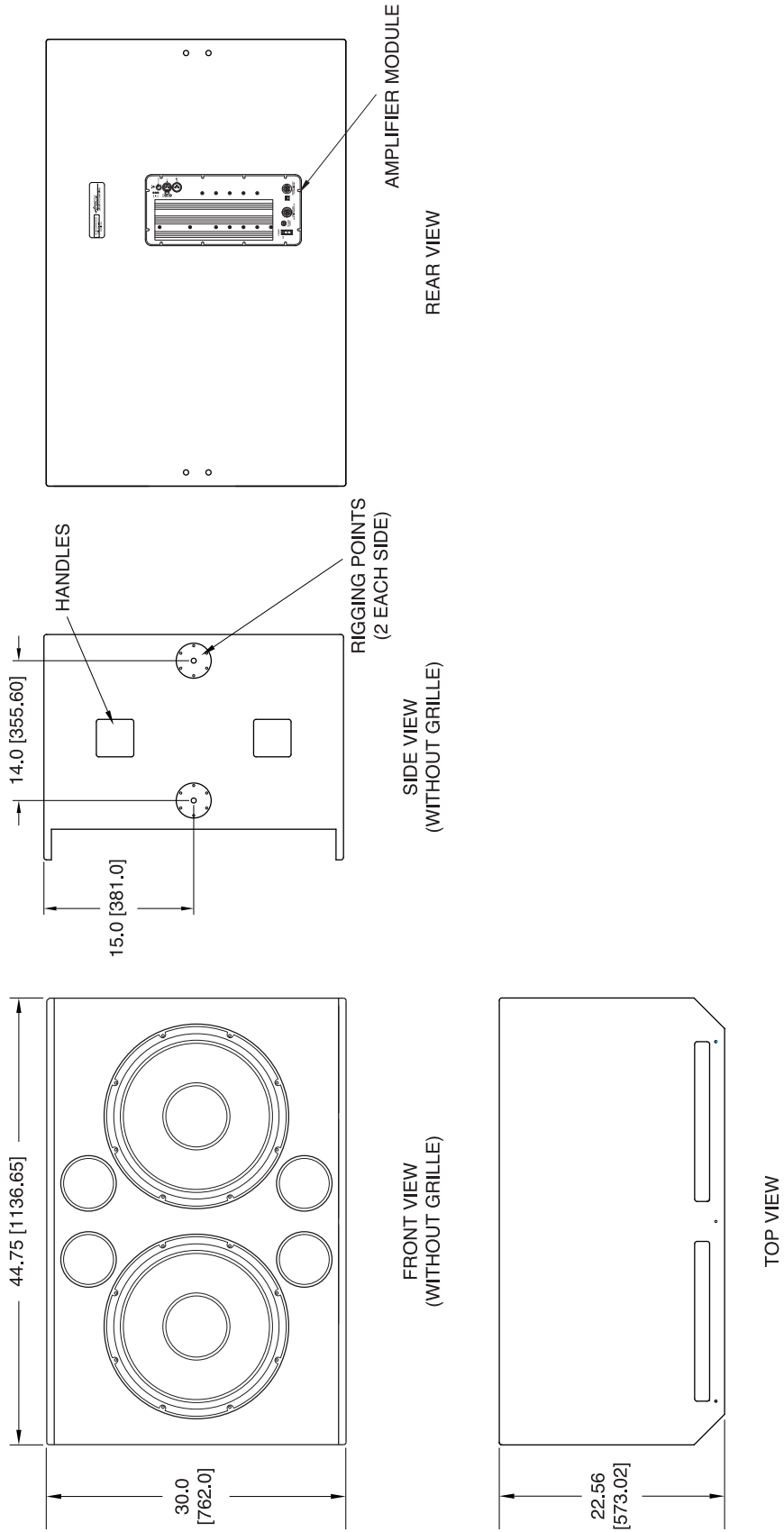





## LIMITED WARRANTY; EXCLUSION OF CERTAIN DAMAGES

Apogee Sound International's self-amplified speaker products are warranted to be free from defects in materials and workmanship, under normal use and service, when installed and operated in accordance with product specifications, from the date of original purchase for a period of three (3) years.

If any part of the equipment covered by this warranty malfunctions, it will be repaired or replaced, at our option, provided the equipment is shipped prepaid to an authorized Apogee Service Facility.

This warranty does not extend to finish; appearance items; or any product malfunctions due to abuse, accident, misuse, negligence, misapplication or operation under other than specified conditions, or if altered in any way; nor does it extend to incidental or consequential damages of any kind.

**THIS LIMITED WARRANTY IS OUR SOLE AND EXCLUSIVE WARRANTY AND THE PURCHASER'S SOLE AND EXCLUSIVE REMEDY. APOGEE SOUND INTERNATIONAL MAKES NO OTHER WARRANTIES OF ANY KIND, EXPRESS OR IMPLIED, AND ALL IMPLIED WARRANTIES OF MERCHANTABILITY AND FITNESS FOR A PARTICULAR PURPOSE ARE HEREBY DISCLAIMED AND EXCLUDED.**

Before returning products for warranty or non-warranty repair or replacement, call the Customer Service Department to obtain a factory-issued Return Merchandise Authorization (RMA) number, and make sure the freight charges are prepaid. Merchandise returned without an RMA on the outside of the box will not be accepted.

Apogee Sound International  
Customer Service Department  
50 Spring Street  
Ramsey NJ 07446, USA  
Tel: 800-999-2809  
Fax: 800-999-9016

The salespersons or agents of Apogee Sound International, or its dealers, are not authorized to make any representations, promises, or warranties regarding products on behalf of Apogee Sound International or in any manner obligate Apogee Sound International to the purchaser.

This warranty applies only to products sold in the United States. Please consult your Apogee Sound International distributor for warranty information, service, and parts outside of the United States.



50 Spring Street, Ramsey, NJ 07446, USA  
Tel. 201-934-8500, Fax: 201-934-9832  
[www.apogeessound.com](http://www.apogeessound.com)